

# **TENMA<sup>®</sup>**

**Model 72-8180**  
Analog Volt/Ohm Meter

INSTRUCTION MANUAL

Tenma Test Equipment  
[www.tenma.com](http://www.tenma.com)

## Controls and Functions

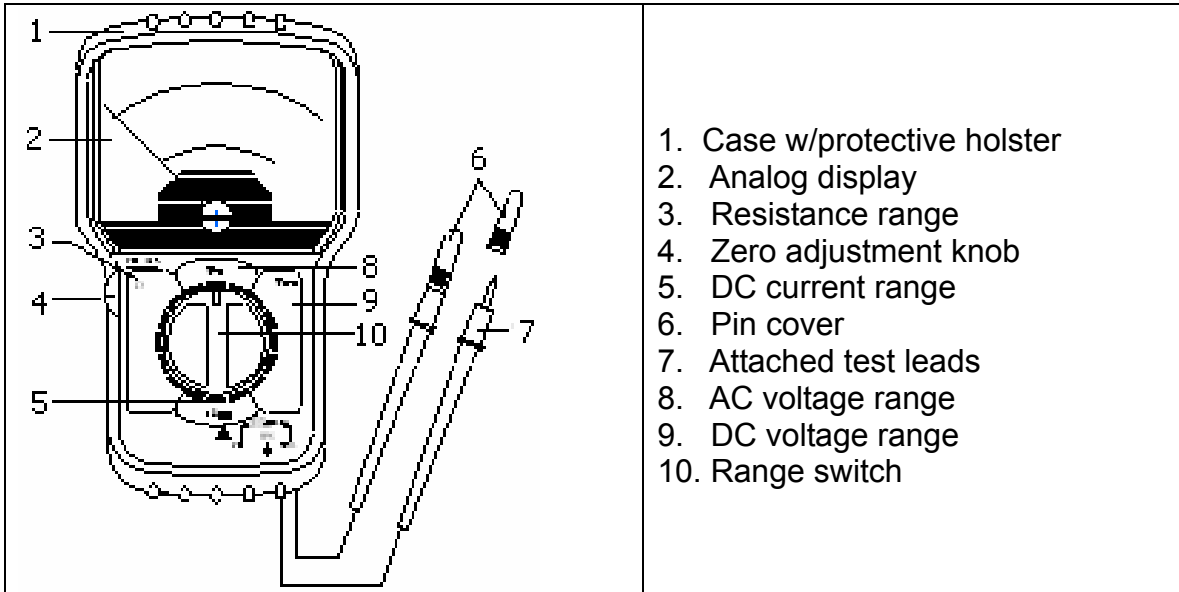

1. Case w/protective holster
2. Analog display
3. Resistance range
4. Zero adjustment knob
5. DC current range
6. Pin cover
7. Attached test leads
8. AC voltage range
9. DC voltage range
10. Range switch

## Specifications

Function	Measurement Ranges	Accuracy	Remarks
DCV	2.5V, 10V, 50V, 250V and 500V	±3% full scale	Input impedance 2KΩ/volt
ACV	50V, 250V and 500V	±4% full scale	Input impedance 4KΩ/volt
DCA	50μA, 5mA, 500mA	±3% full scale	
Ohms	x1Ω, x10Ω, x100Ω, x1KΩ and x10KΩ	±3% of arc	

Operating temperature range:	5~40° C
Relative humidity:	≤75%
Power source:	1.5V AA (x1), plus 9V (x1)
Fuse:	0.5A fast blow, 5 × 20mm
Dimensions:	6.1" (H) × 3.5" (W) × 1.9" (D)
Included accessories:	Test leads, instruction manual

## Safety

- This meter is designed for indoor use at temperatures between 5° ~ 40°C (40°~105°F) and altitude up to 2000m (6560’).
- To ensure that the meter is used safely, follow all safety and operating instructions in this manual. If the meter is not used as described in this manual, safety features may be impaired.

## Operation Warnings

- Important Note: Never apply more than 500V AC/DC to the input terminals. Exceeding this could lead to equipment damage or personal injury.
- Disconnect test leads from device under test prior to selecting different measurement ranges.
- When measuring voltage, be certain the instrument is not switched to a current or resistance range.

- Use extreme care when measuring voltage above 50V, especially from sources where high energy exists.
- Avoid making connections to “live” circuit whenever possible.
- When making current measurements make sure power is off while making connections.
- Before making resistance measurements, be certain no voltage is present in the circuit under test. Also discharge any associated capacitors.
- Always ensure that the correct function and range is selected. If in doubt about the correct range, start with the highest and work down.
- Extreme care should be taken when using the instrument to conjunction with a current transformer connected to the terminals. High voltage may be produced at the terminals if an open circuit occurs.
- Ensure that the test leads and probes are in good condition with no damage to the insulation.
- Take care not to exceed the over-load limits as given in the specifications.
- When replacing fuse, use only the specified value.
- Before opening the case of the instrument to replace the battery or fuse, disconnect the test leads from any external circuit, set the selector switch to “OFF” position.

### **DC Voltage Measurement**

- Set the range selector to the proper DCV position.
- Keeping certain to observe correct polarity, connect the test leads in parallel to the load to be measured.
- Read the value on the DC scale, be sure to use the correct scale for the range selected.

### **AC Voltage Measurement**

- Set the range selector to the proper ACV position.
- Connect the test leads in parallel to the load to be measured.
- Read the value on the AC scale, be sure to use the correct scale for the range selected

### **DC Current Measurement**

- **Important Note:** Never use to measure current in a circuit with more 240VDC. Never attempt to measure AC current with this meter.
- Set the range selector to the proper DC mA position.
- Connect the test leads in series to the load to be measured. In other words, the meter must be part of the circuit to be measured.
- Read the value on the DC scale, be sure to use the correct scale for the range selected

### **Resistance Measurement ( $\Omega$ )**

- **Important Note:** Make sure that no voltage is present in the circuit to be measured, including discharging of any associated capacitors. Even small voltage levels can cause permanent damage if applied to the meter while in the OHMS range.
- Set the range selector to proper  $\Omega$  position
- “Zero” the meter. This is accomplished by simultaneously connecting the two probe tips together, and rotating the OHMS ADJ control until the meter displays “0” ohms. If a 0 $\Omega$  reading cannot be obtained, the meter batteries are low and should be replaced.
- Connect the test probes to the circuit or device under test. Make certain not to touch the metal probe tips with your fingers, as your body resistance will affect the reading.
- Read the value on the OHM scale and multiply it by the multiple designated by the range you have selected.
- For best accuracy, select a range that will provide a meter reading closest to the center of the scale.
- To obtain accurate readings, perform the Zero meter function each time the OHMS scale is changed.

### Decibel (dB) Measurement

- Set the range selector to one of the ACV ranges.
- When using the 50V range, read the measurement directly from the dB scale.
- When using other scales, you must add the appropriate number of dB as noted on the following table:

ACV Range	50V	250V	500V
Add dB	0	14	20

- Note: For Absolute dB measurement, circuit impedance must be  $600\Omega$ ,  $0\text{ dB}=1\text{mW}$  dissipated in a  $600\Omega$  load.
- For the signal with DC component, connect a capacitor with value greater than  $0.1\mu\text{F}$  between test probes and circuit under test.

### Cleaning and General Maintenance

- Periodically wipe the case with a damp cloth and mild detergent. Do not use abrasives or solvents.
- Periodically clean terminals and test probes with standard spray contact cleaner as dirt and moisture affect readings.
- Turn the Meter to OFF position when it is not in use and remove the batteries if the meter is not to be used for a long period of time.
- Do not attempt to repair or service your Meter unless you are qualified to do so and have the relevant calibration, performance test, and service information.
- To avoid electrical shock or damage to the Meter, do not allow water inside the case.
- Do not store the Meter in a place of high humidity or temperature

### Battery Replacement

- When using the OHMS scale, if the meter cannot be calibrated to the Zero position, the batteries should be replaced.
- Make certain the test leads are removed from the circuit under test.
- Remove the three Philips head screws from the rear of the meter housing
- Remove the rear housing from the meter assembly.
- Locate and replace the batteries inside the meter (1x AA) and (1x 9V).
- It is recommended that only good quality alkaline batteries be used.
- Replace the rear housing and reinstall the screws.

### Replacing the Fuse

- Make certain the test leads are removed from the circuit under test.
- Remove the three Philips head screws from the rear of the meter housing
- Remove the rear housing from the meter assembly.
- Locate and replace the fuse in its socket located on the surface of the internal PC board.
- Replace with only a comparable 5mm x 20mm 0.5A 250V fast blow type fuse.
- Replace the rear housing and reinstall the screws.
- Important Note: Replacement of the fuses is seldom required. A blown fuse is always a direct result from improper meter use.

**Tenma Test Equipment**  
**405 S. Pioneer Blvd.**  
**Springboro, Ohio 45066**  
**www.tenma.com**

# 72-8180

